

US FARM SYSTEMS

BELT DRIVEN STATIONARY AGITATOR PUMP

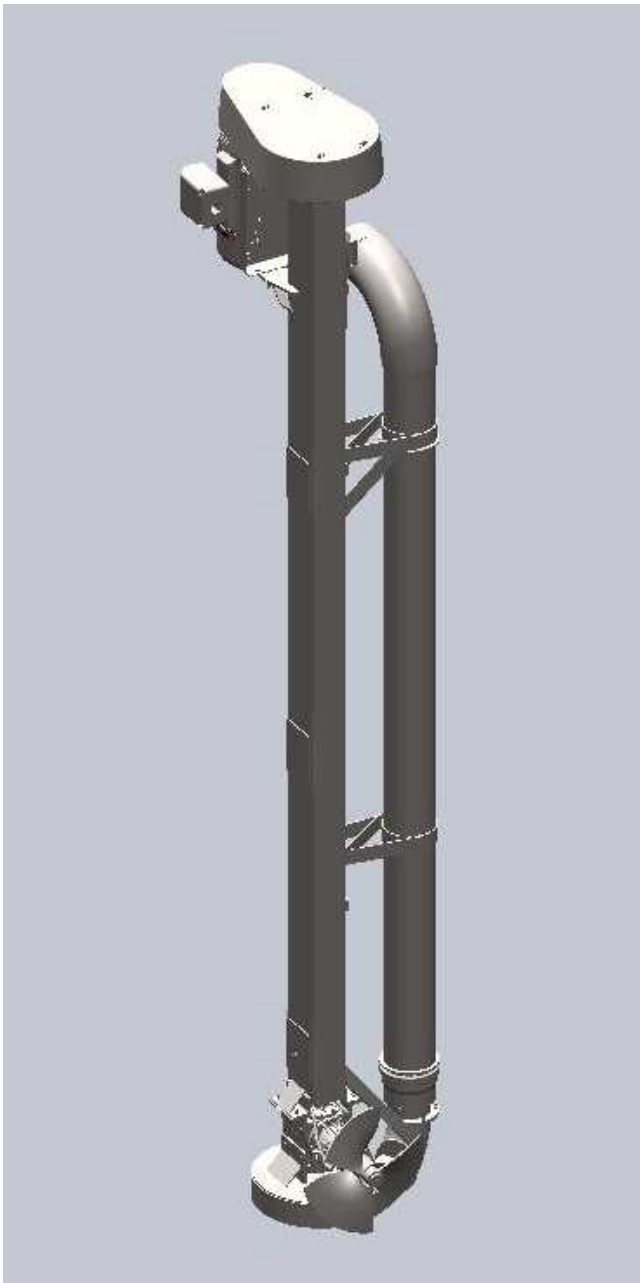

MAINTENANCE AND REPAIR

US FARM SYSTEMS
2955 S. K Street
TULARE, CA 93274
800-811-9462
(559)685-0340
FAX (559)685-9160

Website www.usfarmsystems.com

Stationary Agitator Pump - Belt Driven

Table of Contents

Illustration	3
Important Installation Instructions	4
Important Information About US Farm System's Pumps	5
Description	6
Maintenance	
Every 100 Hours (Every 4 Days if Run Time is 24/7 or 12 Days if 8/7).....	7
Every 300 Hours (Every 12 Days if Run Time is 24/7 or 36 Days if 8/7).....	7
Yearly.....	7
Before You Start.....	7
Pump Removal.....	7
Impeller - Disassembly and Inspection.....	8
The Impeller.....	8
Impeller Removal	9
Impeller Condition and Fit.....	9
Impeller, Reinstallation	9
Propeller and Knife Condition and Fit.....	10
Repair	
Drive shaft Removal	10
Before You Start.....	10
Top Bearing Removal.....	10
Pump Housing Removal	11
Pump Housing Reinstallation	11
Pulley Removal - Shaft and Motor.....	12
Pump Reinstallation.....	12
Propeller and Knife Removal	12
Gearbox Removal.....	13
Gearbox Reinstallation	13
Propeller and Knife Reinstallation	13

Stationary Agitator Pump - Belt Driven

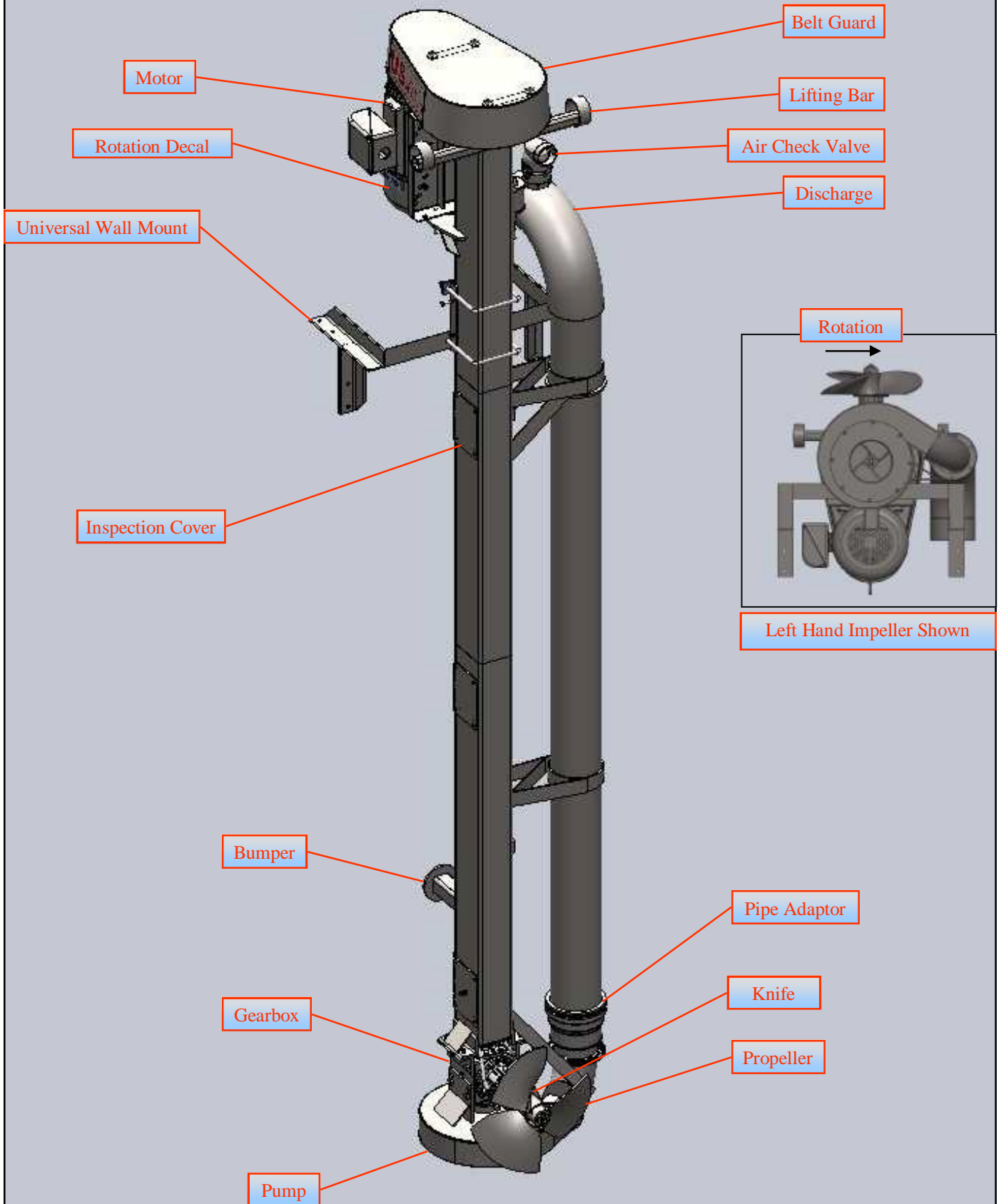

Stationary Agitator Pump - Belt Driven

ATTENTION

Installation Instructions

Pump must rotate in the direction of the outlet - See rotation sticker on the motor (see page 3).

Make sure the "feet" on the pump are resting on the bottom of the pit and the "bumper" is against the wall before anchoring the u-bolts (see page 3).

Check the pump motor amp draw as follows:

NOTE - The more water the pump moves, the more amps the motor will draw. If there is a restriction in the piping or the outlet valves are not open the amp reading will be lower than normal.

1. Make sure there is no restriction in the piping
2. Make sure the outlet valves are open as they would be in normal pump operation.
3. Check the allowable amps on the placard on motor.
4. Set-up amp meter and start the pump. Initial reading may be high until the piping is full.
5. If the amp readings are within the range specified, a qualified electrician should set the overload to 10% above usage to protect the motor.

AMPS Too High

1. It will be necessary to reduce the pump speed or pump flow. Call US Farm Systems, 1-800-811-9462. **DO NOT** run the motor if the amp readings are too high. The motor will be damaged and warranty will not cover the loss.

Service

Grease according to the instruction labels on the service points.

Re-tighten the belts after 1 month of operation.

Stationary Agitator Pump - Belt Driven

Important Information About US Farm Systems Pumps

Pump Rotation

Most pumps rotate in a counter clockwise direction. If you are in doubt about rotation, see page 3.

When removing and reinstalling a pump, always mark the wires as they are disconnected. If unsure, remove the belts and check motor rotation.

Impeller Fit

When new, the clearance between the front and back of the impeller and the housing is close. When reassembling a used pump, first make sure the clearance between the wipers on the back of the impeller is set as close as possible to “zero” clearance. Allowable clearance from housing plate to top of impeller plate is 11/16” maximum (Shown Below-Impeller Wiper Gauge).

Impeller-to-intake plate clearance should be 1/16” to 1/8” max. This can be achieved by machining the collar on the intake plate (Fig 6). A pump will operate with excessive intake plate clearance, but will be less efficient.

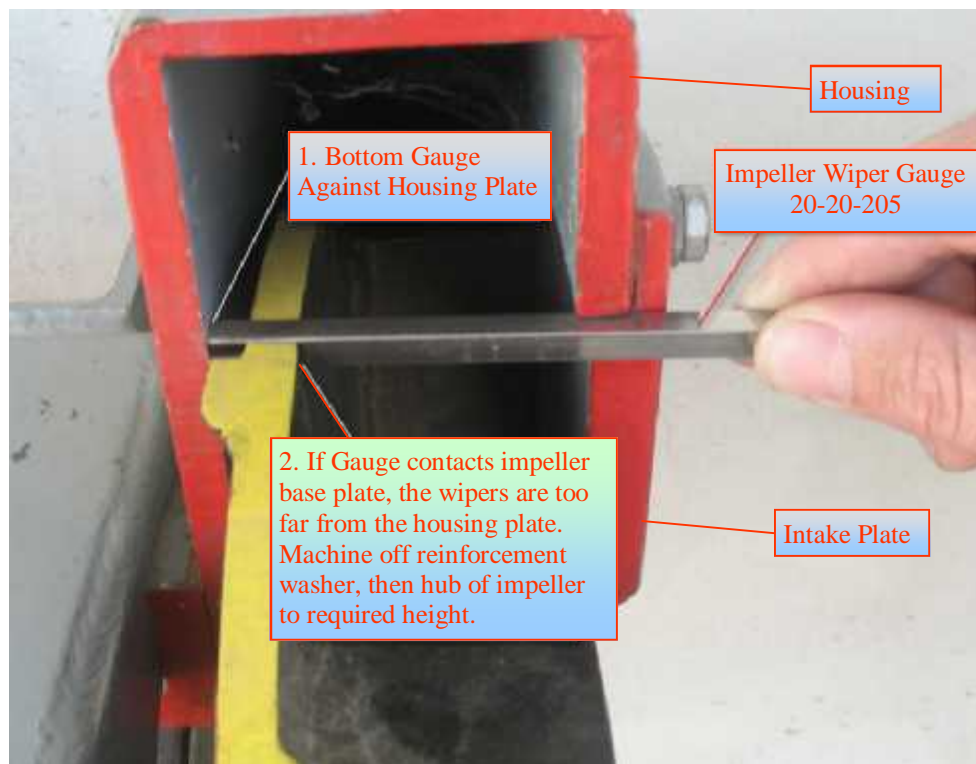

Bearings

When disassembling an old pump, frequently parts will be “seized” to each other. If you use a steel hammer to try to dislodge shafts, yokes, and bearings, you will almost certainly damage the bearings. Generally, it is a wise idea to plan on replacing most of the bearings when reassembling a pump.

Stationary Agitator Pump - Belt Driven



DESCRIPTION

The U.S. Farm Systems Stationary Agitator Pump is designed to empty primary waste drainage pits. Basic construction of these pumps is similar, with the length and motor/pump size being the primary difference.

The gearbox is turned by a series of belt driven shafts connected by u-joints. Each u-joint connection is supported by a bearing. The center of the tube is designed to remain dry to protect bearings and u-joints.

Most major maintenance requires removal of the pump from the pit.

Important - Many dairymen use a paraffin based, water proof grease. **DO NOT** lubricate any part of the pit pump with this type of grease. **Use Lubri-plate # 1242 or equivalent.**

Stationary Agitator Pump - Belt Driven



Fig 1 Grease Zerks

Every 100 hours (Right Sticker)

1. Add 45 shots from grease gun to both remote grease zerks (Fig 1) at the top of the pump support housing.
2. Run the motor and check for noise and vibration.



Fig 2 Grease Zerk

Every 300 hours (Left Sticker)

1. Remove belt guard and check condition and tension of the belts. Grab the belt midway between the two pulleys and twist the belt. When properly adjusted you should be able to twist the belt 90°. If belts are frayed or worn, then replace. Always replace belts as a matched set. DO NOT add one new belt.
2. Add 4 shots from grease gun to top bearing (Fig 2), just beneath large pulley.
3. For motor maintenance see Worldwide Electric Three-Phase Motors at <http://www.worldwideelectric.net/Brochures/Brochures.html>

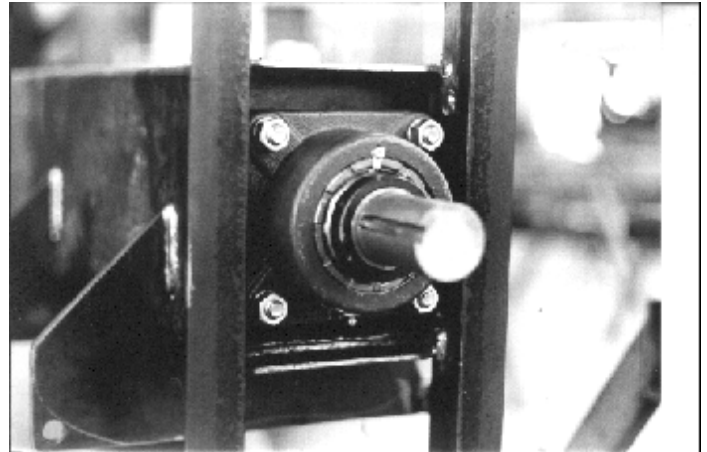

Fig 3 Top Bearing (Pulley Removed)

YEARLY

Before You Start

Yearly maintenance is primarily an inspection process to make sure the bearings, shafts and seals are in good condition.

Check carefully inside the beam. A small amount of condensation can be considered normal but if there is evidence of water contamination then all the bearings should be carefully checked,

Yearly maintenance requires removal of the pump from the pit. This procedure also requires the following special tools:

- 1 tube of Clear Silicone
- Stands or blocking to hold pump housing 30" off ground
- Never-Seize
- Loctite 271

Generally pumps that have been in operation for a year will require replacement of some items. Before starting, it is good idea to have the following items on hand:

- Knives and knife holders for the intake plate (Fig 9)

Pump Removal

1. Shut-off the circuit breaker or main switch that supplies power to the pump motor.

WARNING

DEATH OR INJURY CAN OCCUR

High voltage may be available at the motor if the power supply is not properly disconnected.

Stationary Agitator Pump - Belt Driven

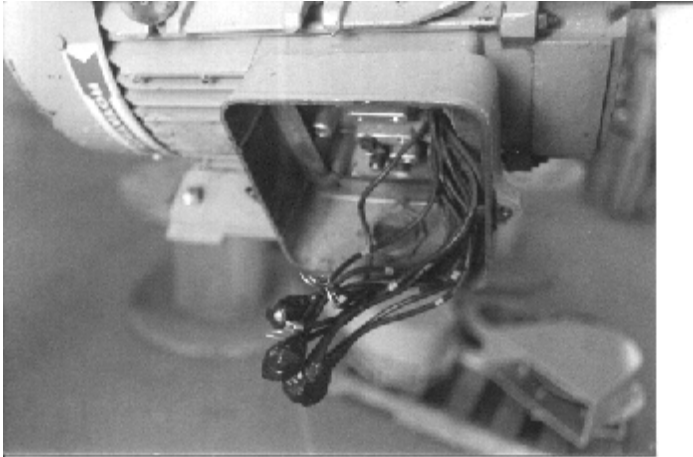

Fig 4 Disconnecting Wires

2. Wires can be disconnected at the main junction box or at the motor. If the wire run to the main box is not too long, disconnect at the main box. Clearly mark each of the three wires for reinstallation. Disconnecting at the motor junction box is possible but you will encounter more wires and it is frequently difficult to remove and reinstall the junction box cover.

WARNING

DEATH OR INJURY CAN OCCUR

Complete pump assemblies can weigh 1500 to 2500 lbs. They are also top heavy on the motor end. Lift with extreme caution.

Make sure you have a lifting device capable of supporting at least 2500 lbs.

3. Removal from the pit.
 - a. Disconnect discharge pipe.
 - b. Attach chains around lifting bar on pump assembly. Test for secure mounting of lifting chains.
 - c. While lifting chains are tight, loosen and remove the u-bolts attaching the pump to anchors.
 - d. Remove from the pit and place across blocking 30" high, motor side down.
Make sure pump is in a **securely** clamped down position before proceeding.
4. Remove the inspection cover(s) along the side of the beam. Check for any signs of moisture inside beam. Moisture may indicate failure of seals in gearbox and can cause failure of bearings inside the beam.

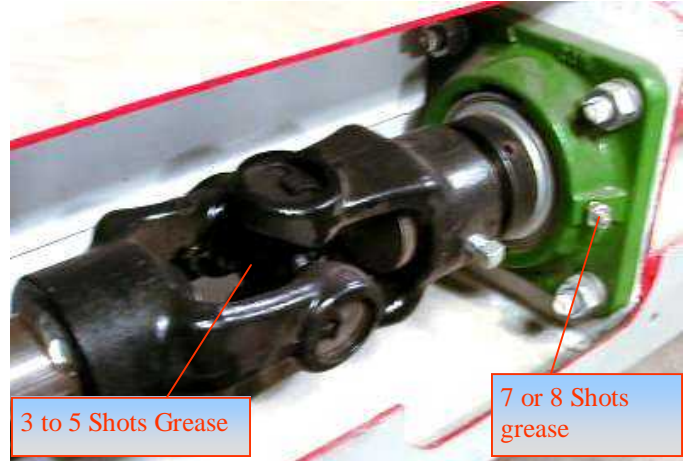

Fig 5 Grease Bearings and U-joint

5. Grease each bearing and u-joint. **DO NOT use paraffin based water proof grease.** Do not reinstall covers at this time.

Impeller- Disassembly and Inspection



Fig 6 Impeller

The impeller is the high wear item in the pump. When assembled at the factory, the clearances between the housing and the front and back of the impeller are very close. As the wipers on the back of the impeller and the blades on the front wear, this clearance increases. It is **very important** when reassembling a pump, to maintain a tight clearance between the wipers on the back-side and the housing. This operation usually moves the impeller away from the intake plate.

Stationary Agitator Pump - Belt Driven



Fig 7 Pump Housing Removal

Impeller Removal

1. Remove 8 bolts attaching intake plate and remove intake plate. Flatten center impeller washer then remove center bolt. If impeller can be removed with small pry-bars or vice-grips, step 2 is not needed.

Note: Before removing the impeller, check the clearance between the impeller wipers and the housing. Save this information for future use.

2. Weld to center of impeller a 2 1/2" pipe that is about 3' long. Attach slide-hammer and remove impeller. Grind to remove pipe from impeller.
3. Inspect housing and impeller for abnormal wear.
4. Grind off weld from side of bolts, (Fig 15) and remove bolts.
5. Cut tie bar, as shown (Fig 7).
6. Remove the pump housing. The outlet pipe is a slip fit, with a rubber seal ring.

Impeller Condition and Fit

Note: The clearance between the impeller wipers and the housing is one of the most important settings on a pump. Improper fit will cause premature failure.

1. Check the wiper blades on the backside of the impeller. New wipers are 1/4" thick. If wipers are badly worn, they should be replaced or a new impeller installed.

Note - If the impeller is in good condition but the wipers are worn, the wipers can be machined off and new ones installed. This can save the cost of a new impeller.

2. Check the general condition of the impeller blades. If they are badly worn or bent, the impeller should be replaced.

Note - If the impeller housing is in good condition no shims are needed.

3. Trial fit the impeller by installing the shims (if used) that were removed. Slide the impeller with key on the shaft and check the clearance between the wipers and the housing. Ideally the wipers should be as close to the housing as possible. Turn the impeller a full revolution and check the fit. A perfect fit is when the wiper blades just "tick" the housing.



Fig 8 Impeller Wipers

DO NOT put the pump into service if the wiper-to-seal clearance is too large. This will result in premature seal and bearing failure.

Impeller Reinstallation

Once impeller wiper clearance is correct, proceed as follows:



Fig 9 Intake Plate and Knives

Note: Pumps will operate with more than 1/8" intake plate-to-impeller clearance but pump efficiency will be reduced.

1. Remove the drive belts and rotate the shaft to check for free movement. If the shaft turns freely continue. If shaft is hard to turn or has a hard spot, locate the source of this problem before continuing.
2. Install inspection covers with liberal coating of silicone seal.
3. Reinstall Pump. **See Pump Reinstallation Instructions.**

Stationary Agitator Pump - Belt Driven

Propeller and Knife Condition and Fit

1. Replace propeller if cracks, excessive wear, or bent blades appears.
2. If knife has excessive wear to area between propeller and knife so bolts protrude into propeller, replace knife. If dull, sharpen with grinder.

Driveshaft Removal

Before You Start

The shafts, u-joints and bearings inside the beam are all slip fit and keyed when installed at the factory. All parts are coated with Never-Seize when assembled. Bolts and set screws use Locktite 271. However, it is not unusual for these parts to “seize” and become very difficult to remove. Hammering and prying on these components subjects the u-joint bearings and flange bearings to high loads and will usually cause bearing failure.

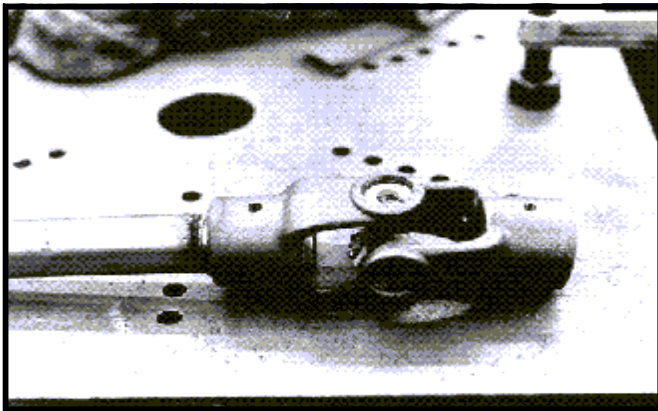

Fig 10 Drive Shaft & U-Joint

Sometimes heating a u-joint yoke will loosen it enough for removal but you run the risk of damaging the u-joint bearings. Flange bearings can be especially difficult to remove from the shaft and they cannot be heated without damaging them.

U-joints can be removed by using a cutting torch to cut each side of the yoke and then use a hammer and chisel to split the yoke. Try not to damage the shaft while doing this.

There is not an easy way to remove a bearing that has seized to the shaft. Heat or hammer blows will destroy the bearing. Again a cutting torch can be used to remove the bearing but use care to not damage the shaft.

In each case, you will have to use your own judgment as to the best possible way to disassemble these parts.

Top Bearing Removal

1. Remove belt guard and drive belts.
2. Remove pulley.

3. Loosen bearing lock collar and remove four retaining nuts and lock washers from bearing.

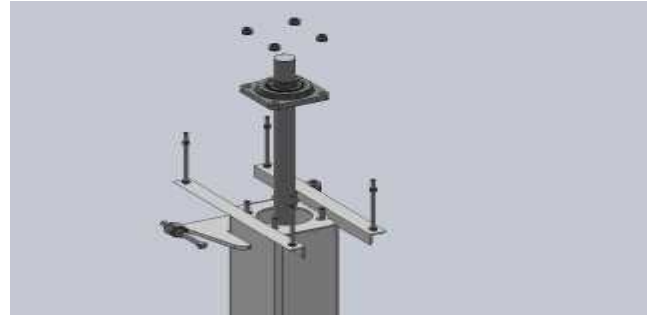

Fig 11 Top Bearing Removal

4. At the first inspection hole, loosen the set screw on the bottom portion of the u-joint and remove first shaft and u-joint through the top of the housing with the top bearing attached (Fig 11).

Note: The top yoke of the u-joint is welded to the top shaft. The bottom yoke is held in place by a set screw and key. It is not welded to the second shaft. In some cases, the u-joint slides easily off the bottom shaft. If this is not the case, pushing and prying on the yoke and/or pulley may help. If you beat on the shaft with a metal hammer, the flange bearing just below the u-joint will be damaged.

If all else fails, try heating the yoke but try not to over-heat the yoke bearings or the flange bearing just below the yoke. If the u-joint will not release from the shaft, use a cutting torch to split the bottom yoke in half.

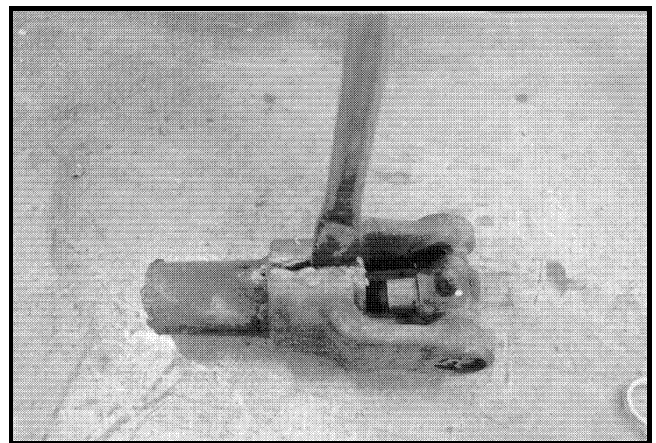

Fig 12 Splitting Yoke (Shown on Bench)

5. Loosen the set screw in the flange bearing eccentric lock collar and remove the collar. Lock collar rotates opposite the direction of shaft rotation. Loosen the four retaining nuts on the flange bearing and remove the bearing by sliding it over the shaft.

Stationary Agitator Pump - Belt Driven

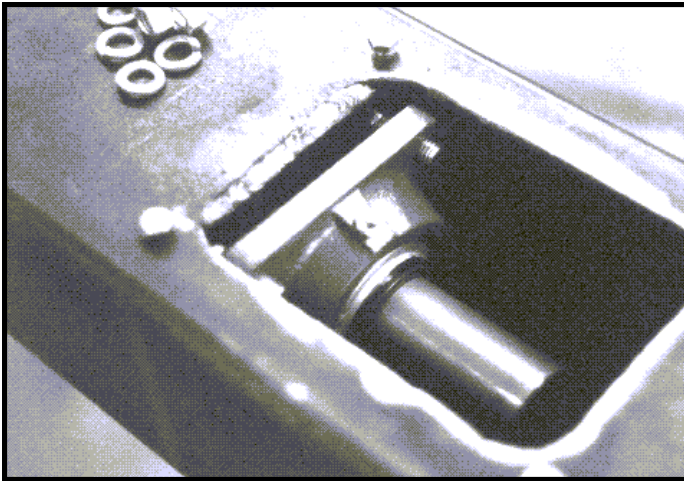

Fig 13 Removing Flange Bearing

Note- Clean the shaft and remove burrs before attempting to remove bearing. If you beat on the bearing housing with a metal hammer, you will damage the bearing. In extreme cases, use a cutting torch to remove the bearing.

6. Go to the next lower inspection hole (if applicable) and repeat the same procedures as Step 4. The bottom shaft has 6-spline yoke welded to end of shaft so it will slide on spline end of gearbox. There is no bottom bearing or seals as gearbox contains bearings and seals to prevent leakage.
7. Once all shafts and bearings are removed, check each for wear and damage. Questionable parts should be replaced.
8. Re-assemble in reverse order. Flange bearing lock collars rotate in the direction of shaft rotation when installing. Apply a *liberal* coating of Never Seize to all sliding parts and use Loctite 271 on all bolts. Once installed, grease all bearings and u-joints.
9. Rotate shaft and check for free movement.
10. Reinstall impeller and intake plate as described in **Impeller Disassembly and Inspection**.
11. Re-install and re-tension belts. See **Pump Reinstallation and Testing**.

Pump Housing Removal

As you disassemble, always check pump housing, impeller and shaft for abnormal signs of wear. A worn, out-of-balance impeller can destroy seals and bearings in just a few hours of operation.

1. Remove 8 bolts attaching intake plate and remove intake plate. Flatten center impeller washer, then remove center bolt. If impeller can be removed with small pry-bars or vice-grips, step 2 is not needed.



Fig 14 Impeller

2. Weld to center of impeller a 2 1/2" pipe that is about 3' long. Attach slide-hammer and remove impeller. Grind to remove pipe from impeller.
3. Inspect housing and impeller for abnormal wear.
4. Grind off weld from side of bolts and remove bolts (Fig 15).
5. Remove the pump housing. The outlet pipe is a slip fit with a rubber seal ring.



Fig 15 Pump Housing Attaching Bolts

Pump Housing Reinstallation

1. Tighten 4 bolts that attach gearbox to housing.
2. Install impeller with keyway, reinforcement washer, flat washer, and bolt.
3. Tighten center bolt.
4. Clamp impeller to impeller housing on opposite sides.
5. Weld reinforcement washer to impeller.
6. Tack weld flat washer in two places opposite each other.
7. Remove clamps.
8. Bend flat washer up on both sides of bolt.

Stationary Agitator Pump - Belt Driven

9. Once all components are installed, check for free rotation of the impeller and shaft. Movement should be snug but free with no hard spots. This may require removing impeller and use a .045" shim as a spacer, to back side of impeller collar.

Pulley Removal - Shaft & Motor

The pulley on the motor and shaft, are both installed with taper lock bushings. If they need to be removed, proceed as follows:

1. Remove the belt guard and belts.
2. Remove the bolts in the taper lock bushing.



Figure 16 Pulley Removal

3. Install the bolts in the **THREADED** holes in the top of the bushing. Tighten these bolts until they just contact the pulley.
4. Tighten each bolt one quarter turn at a time, until the bushing is free. A few light taps with a hammer may assist in removing bushing.
5. When reinstalling the bushing tighten each bolt 1/4 turn at a time to the maximum torque listed below. Tap the face of the bushing with a metal hammer and recheck torque.

Pump Reinstallation

Type	Bolt Size	Torque (Ft Lbs)
SH	1/4	9
SD	1/4	9
SK	5/16	15
SF	3/8	30
E	1/2	60

Fig 17 Torque Chart

Important Note

Make sure power is off.

If the pump runs backward while the impeller is in the water, you will not pump the quantity of water expected.

If you did not label the wires when removing, or there is any question about pump rotation, connect wires and check for proper rotation before installing. Or, remove belts and check the motor rotation direction (see page 3). Pump rotates in the direction of the pump housing outlet.

1. Place the pump in the pit. Make sure the "pump feet" are resting on the bottom of the pit, and the bumper is against the wall.
2. Reconnect all piping.
3. If you labeled the wires prior to removal, make sure power is off and reconnect the wires.
4. Once all plumbing and wiring is connected, run the pump and check for unusual noise and vibration.
5. Occasionally an air lock will prevent the pump from moving water. If this happens, try cycling the pump Off and On 8 to 10 times.

If this does not solve the problem, disconnect the discharge pipe and repeat.
6. Once the pump is moving water, check the amp draw on each leg of the wiring. The amp draw is only accurate if the pump is moving water as it would under normal operation. Make sure whatever valves that would normally be open are open for this test. Usually amp draw will be high for the first few minutes of operation until the piping is full. If the amp draw exceeds the specifications listed on motor, do not continue to run the pump. This will result in motor failure.
7. Causes of excessive amp draw can be:
 - Pumping too much water. Pulley ratio needs to be changed to slow impeller down.
 - Defective motor

Note: If there is excessive amp draw, call US Farm Systems.

Propeller and Knife Removal

As you disassemble, always check propeller, knife and shaft for abnormal signs of wear. A worn, out-of-balance propeller can destroy seals and bearings in just a few hours of operation.

1. Remove welds, flatten washer and remove center bolt.
2. Remove propeller by sliding off shaft or with slide hammer.

Stationary Agitator Pump - Belt Driven

3. Remove side bolts on knife holder and fittings for grease line from gearbox.
4. Slide knife and knife holder off gearbox.
5. Remove weld between knife and knife holder.
6. Remove welds around reinforcement washer and clean surface between washer and propeller.

Gearbox Removal

1. Remove gear oil line and grease line from gearbox.
2. Remove bottom inspection cover from side of beam.
3. Set support under gearbox with clearance.
4. With propeller, knife holder, and pump removed, remove 4 bolts and welds on ends of angle on gearbox to beam mount.
5. Loosen gearbox shaft to u-joint.
6. Slide gearbox away from beam and out of u-joint.



Fig 18 Gearbox

Gearbox Reinstallation

1. After inspecting gearbox and cleaning gearbox shaft and u-joint.
2. Place new gearbox to beam seal.
3. Align gearbox shaft to spline yoke.
4. Slide gearbox shaft through bottom of beam and into u-joint while insuring compression of seal between gearbox and beam.
5. Replace 4 bolts and nuts on gearbox mount angles (grade 8) and tighten.
6. Insure seal compression.
7. Weld ends of mount angles together and tack weld bolts to angles on gearbox.
8. Replace gear oil line to gearbox and refill reservoir.

Propeller and Knife Reinstallation

1. Clean and remove debris from parts.
2. Inspect parts for cracks, bends and wear.
3. Replace all damaged parts.
4. Set knife holder in place with adjusting bolts loose.
Note: Adjustment can only be made within the distance between grease fitting and clearance hole.
5. Place knife on knife holder. Tighten 4 bolts securing knife to knife holder.
6. Replace grease line fitting.
7. Install propeller and clamp both sides of propeller to knife.
8. Install bolt, flat washer, and reinforcement washer. Weld reinforcement washer to propeller.
9. Release clamps from both sides of propeller and inspect propeller clearance. Propeller should just clear knife.
10. Adjust knife to propeller and tighten adjustment bolts on both sides of knife holder.
11. Bend flat washer up around center bolt and tack weld washer to bolt and reinforcement washer.