

US FARM SYSTEMS

2955 SOUTH K ST.
TULARE, CA. 93274
1-800-811-9462

DESC: CONVEYOR, WELD, 20" X 40'

PART: 30-40-065

M2M REV: 001

ENG: 177-VA

DATE: 8/26/2009

SCALE: 1:48

A

SHEET: 1 OF 5

SW REV:

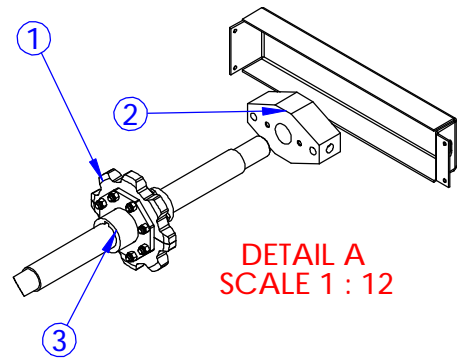

DETAIL A
SCALE 1 : 12

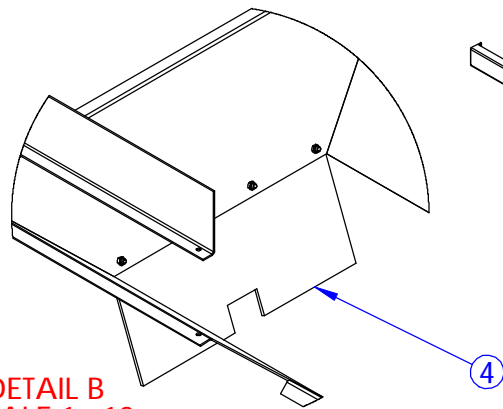

DETAIL B
SCALE 1 : 12

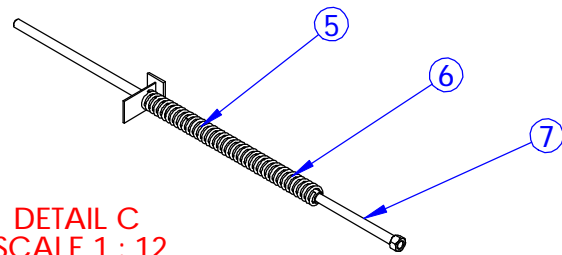
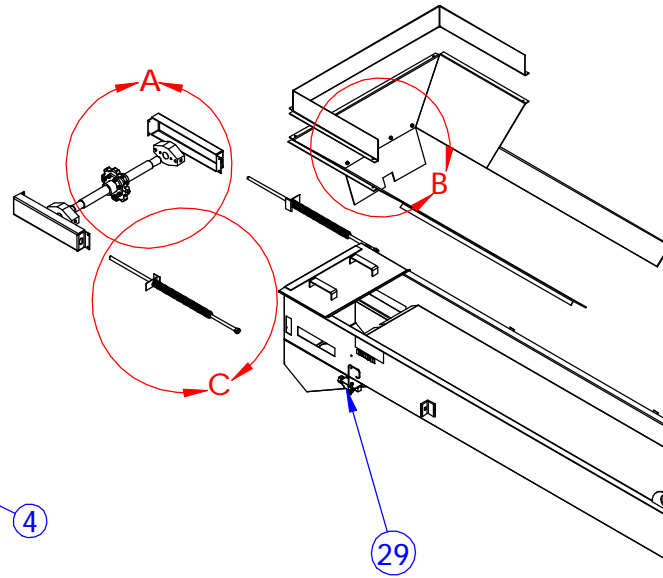

DETAIL C
SCALE 1 : 12

US FARM SYSTEMS

2955 SOUTH K ST.
TULARE, CA. 93274
1-800-811-9462

DESC: CONVEYOR, WELD, 20" X 40'

PART: 30-40-065

M2M REV: 001

ENG: 177-VA

DATE: 8/26/2009

SCALE: 1:36

A

SHEET: 2 OF 5

SW REV:

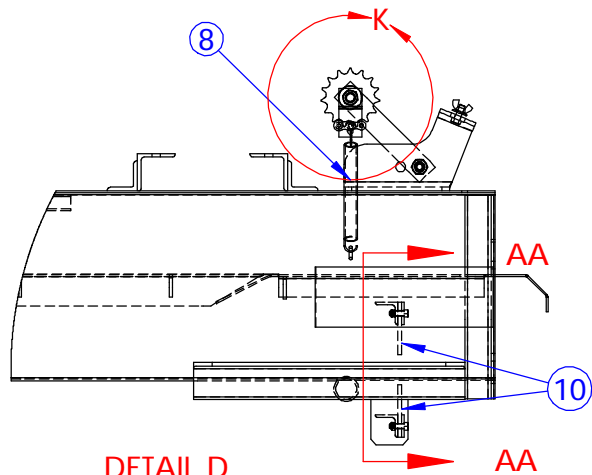
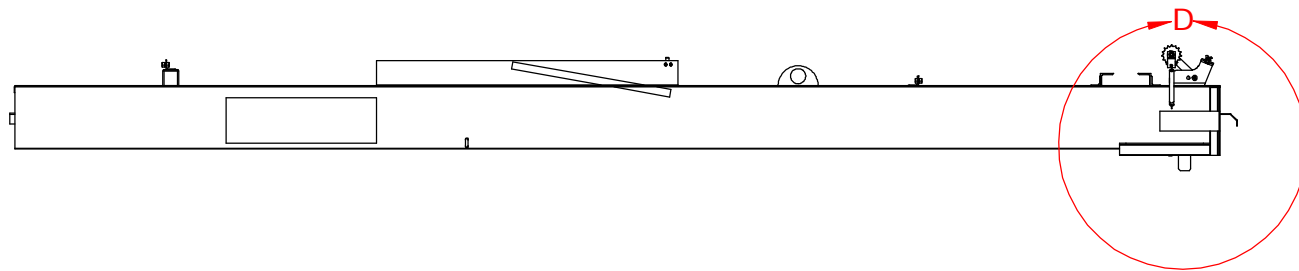

DETAIL D
SCALE 1 : 12

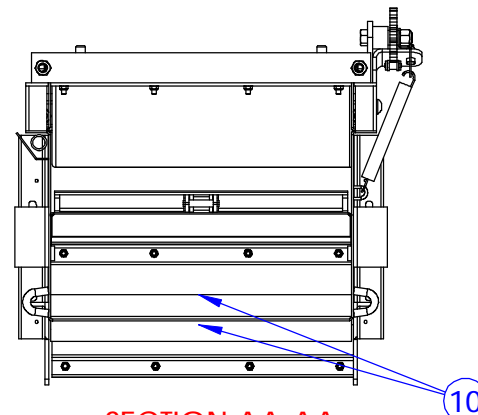

SECTION AA-AA
SCALE 1 : 12

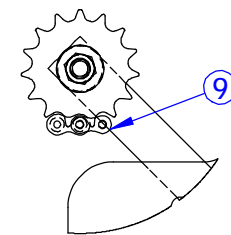

DETAIL K
SCALE 1 : 6

US FARM SYSTEMS

2955 SOUTH K ST.
TULARE, CA. 93274
1-800-811-9462

DESC: CONVEYOR, WELD, 20" X 40'

PART: 30-40-065

M2M REV: 001

ENG: 177-VA

DATE: 8/26/2009

SCALE: 1:36

A

SHEET: 3 OF 5

SW REV:

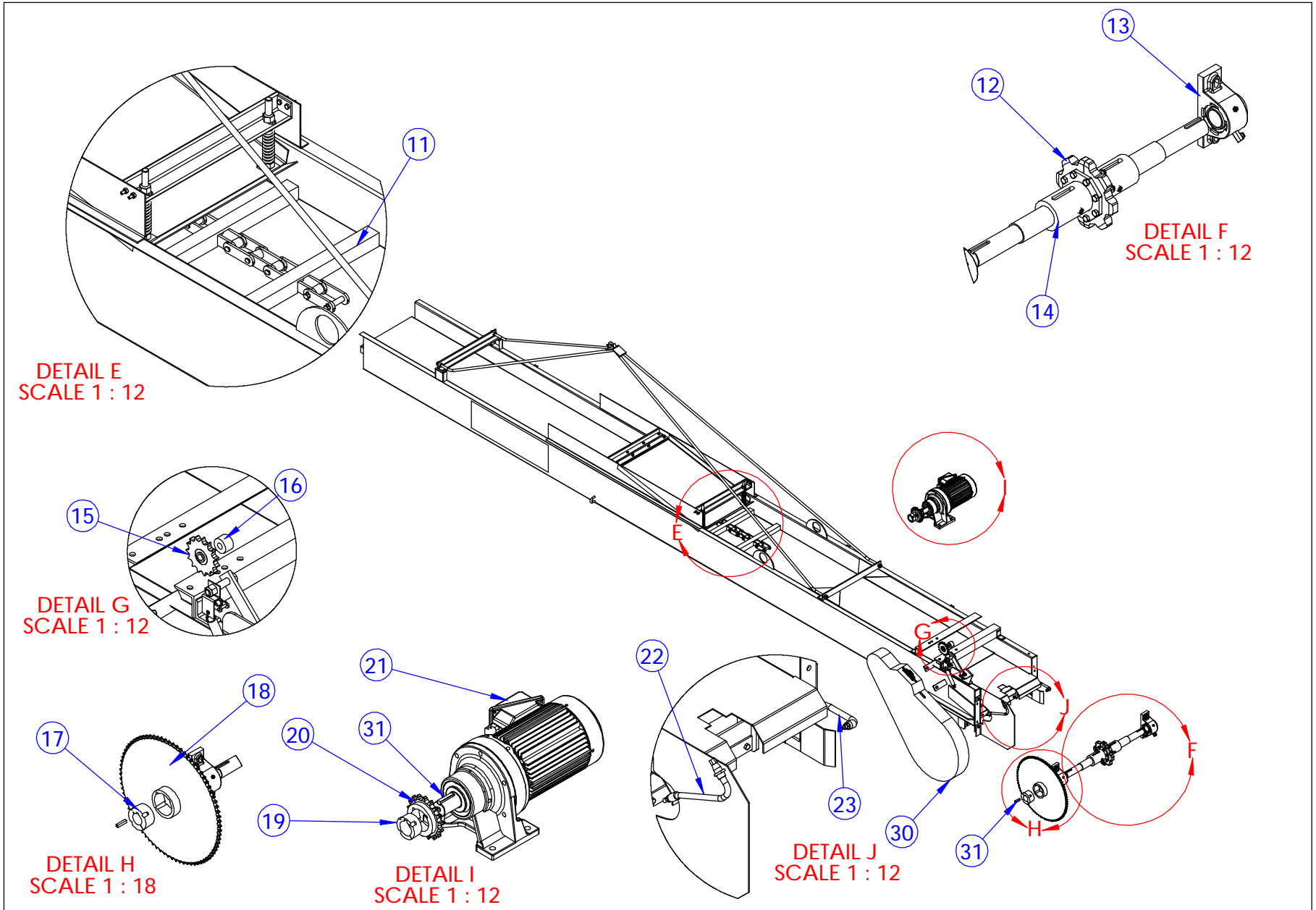

US FARM SYSTEMS	2955 SOUTH K ST. TULARE, CA. 93274 1-800-811-9462	DESC: CONVEYOR, WELD, 20" X 40'			PART: 30-40-065		M2M REV: 001
	ENG: 177-VA	DATE: 8/26/2009	SCALE: 1:36	A	SHEET: 4 OF 5	SW REV:	

G:\SolidWorks\SolidWorks To M2M Transition Dir\177-VA\30-40-065 parts catalog.slddrw 8/26/2009

Item	Description	16"	20"	33"
1	SPROCKET, SS188, SPLT, 2.5" X 7/8"N		30-20-201-1	
2	BEARING, UHMW, MODIFIED		30-30-037	
3	SHAFT, C188, SPLIT, LWR, SGL N	30-40-207	30-40-209	30-40-211
4	FLAPPER, RUBBER, HOPPER	52-10-011	52-10-009	52-10-012
5	GUIDE, SPRING, CONVEYOR		30-20-138	
6	SPRING, 302 S/S, 12"		51-01-300	
7	TENSIONER, CHAIN, 5/8"ALLTHREAD S/S		30-40-155	
8	SPRING, IDLER CONV. #98		51-10-098	
9	CHAIN, DRIVE	64-60-005	64-60-005	64-80-003
10	FLAPPER, RUBBER, CHAIN SCRAPER	52-10-012-5	52-10-012-3	52-10-012-2
11	CHAIN WELD, CONV, SS-188, SGL	30-40-076-1	30-40-062	30-40-091
12	SPROCKET, SS188, SPLT, 3.0" X 7/8"N		30-20-203-1	
13	BEARING, PB, QM, 1-3/4 GREASED		98-10-035	
14	SHAFT, C188, SPLIT, TOP, SGL N	30-40-206	30-40-208	30-40-210
15	SPROCKET, IDLER		see note	
16	TUBING, .641"ID X 1.5"OD X 1"		20-20-092	
17	BUSHING, TAPERLOCK, SHAFT		see note	
18	SPROCKET, SHAFT		see note	
19	BUSHING, TAPERLOCK, MOTOR		see note	
20	SPROCKET, MOTOR		see note	
21	GEARMOTOR, SUMITOMO		see note	
22	HOSE, GREASE, 12" X 1/8MPT X 1/8FPT		92-42-001	
23	HOSE, GREASE, 17" X 1/8MPT X 1/8FPT		92-42-002	
24	SCREEN, WELD, LOWER		see note	
25	SCREEN, WELD, MID		see note	
26	SCREEN, WELD, MID PRESS		see note	
27	SCREEN, WELD, UPPER		see note	
28	GUARD, SHAFT, TOP		see note	
29	SWITCH, COMPACT LIMIT		97-03-001	
30	GUARD, CHAIN, CONVEYOR		30-16-137	
31	KEYSTOCK		see note	

Serial Number required when ordering parts.
NOTE: This part/size/length varies per unit.

US FARM SYSTEMS	2955 SOUTH K ST. TULARE, CA. 93274 1-800-811-9462	DESC: CONVEYOR, WELD, 20" X 40'			PART: 30-40-065		M2M REV: 001	
		ENG: 177-VA	DATE: 8/26/2009	SCALE: 1:96	A	SHEET: 5 OF 5	SW REV:	