

BEAM WELD-ASSY, SABD, SECTIONAL

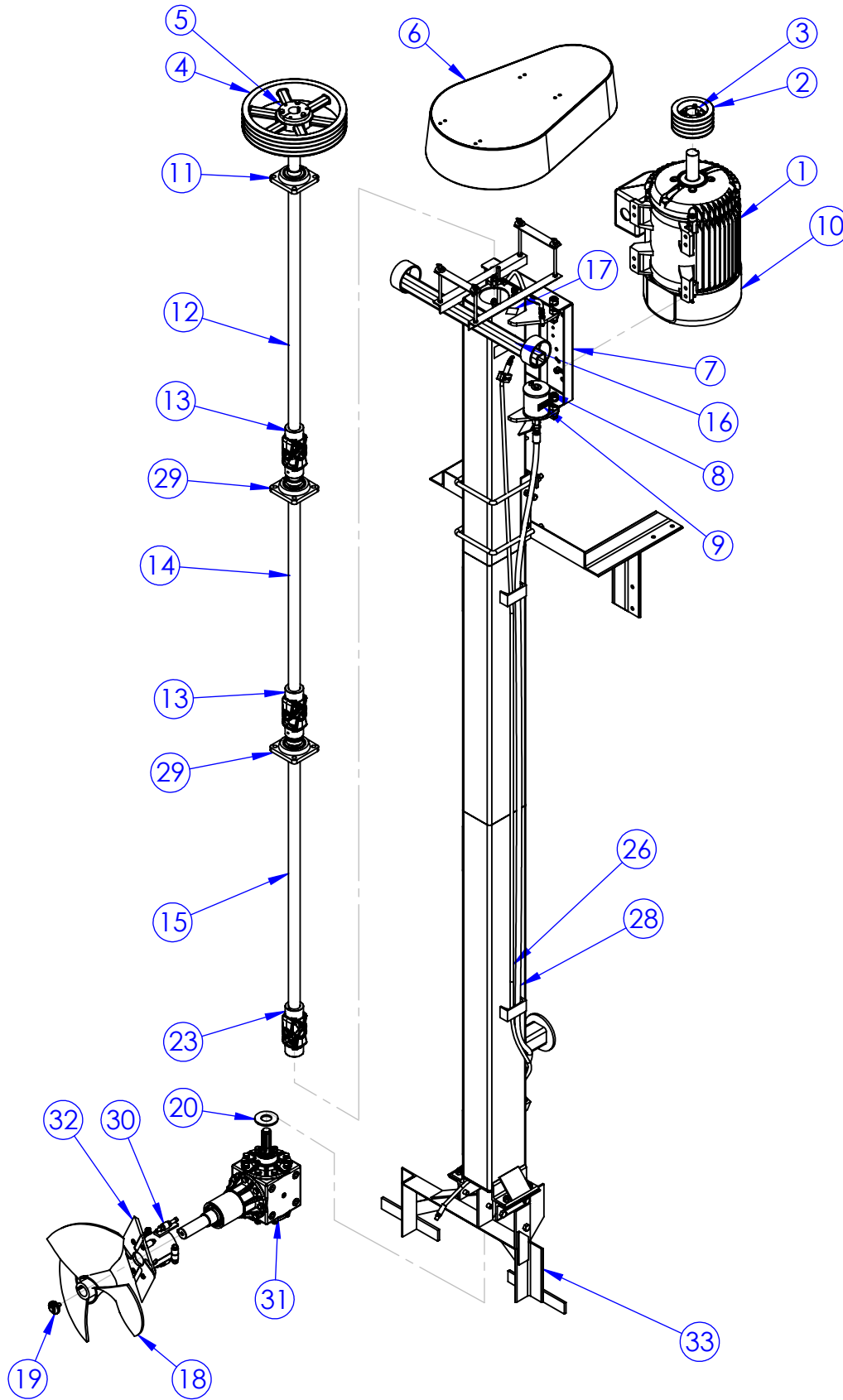

M2M REV: 000

PART: 20-40-222

DESC: BEAM WELD-ASSY, SABD, SECTIONAL

SW REV: A-04

A SHEET: 1 OF 2

SCALE: 1:24

DATE: 7/27/2009

ENG: 294-SS

2955 SOUTH K ST.
TULARE, CA. 93274
1-800-811-9462

US FARM SYSTEMS

G:\SolidWorks\SolidWorks To M2M Transition Dir\294-SS\20-40-222Parts Book.slddrw 7/27/2009

